



Chhattisgarh State Renewable Energy Development Agency (CREDA)

(Dept. of Energy, Govt. of Chhattisgarh)

Near Energy Education Park, Village Fundhar

VIP Road Raipur 492015 (C.G.)

Ph.: 91-8370009925, 26

E-mail: info@creda.in, Website: www.creda.cgstate.gov.in

E.BID DOCUMENT NO.8716/CREDA/HOR/RE-3/Solar Cold Storage/ Cold Room/2018 Date 05-07-2018

**FOR DESIGN, SUPPLY, INSTALLATION & COMMISSIONING OF
SOLAR COLD STORAGE/ COLD ROOM WITH FIVE YEARS ON SITE
WARRANTEE IN VARIOUS SITES OF CHHATTISGARH STATE.**

Important Events and their schedule for this E.Bid are as follows-

S. No	Particulars	Date	Time	Place
1.	Submission of Bid Documents, Technical Bid	06-08-18	Till 11.30 AM	Office of Superintending Engineer (RE - III), Head Office, CREDA
2.	Examination of Bid Documents & Technical Bid	06-08-18	from 12.30 PM	
3.	Submission of Price Bid through http://cspc.co.in	06-08-18	Till 11.30 AM	http://cspc.co.in Web Portal
4.	Opening of Price Bid	06-08-18	After Technical Bid	At Bio Diesel Conference Hall, Near Energy Education Park, VIP Road, Raipur

Bid Document Cost-Rs 5000.00

Document can also be downloaded from our website www.creda.cgstate.gov.in
The cost of bid as mentioned in NIT shall have to be deposited along with the bid document



TABLE OF CONTENTS

S.N.	Description	Page No.
A	Notice Inviting E.Bid	3
B	Check List	4
C	Undertaking by the Bidder	5
D	General Information about this E.Bid	6
E	Eligibility Conditions	7
F	Instructions for Bidders	8-10
G	General Conditions of Contract	11-16
H	Scope of Work	17
I	Technical Specifications	18-20
J	Proposed Layout of Solar Cold Room	21-22
K	Price Bid	23

Ref. No.8716/CREDA/HOR/RE-3/Solar Cold Storage/Cold Room/2018**Date 05-07-2018****A.****NOTICE INVITING E BID**

CREDA invites E.Bids only from Experienced System Integrators of CREDA registered for SPV Projects for FY 2018-19 for standardisation of rates for design, supply, installation, and commissioning of Solar Cold Storage Systems/ Cold Room with five years onsite warrantee in various sites of Chhattisgarh state, as per following details:

S.No.	Item Description	Cost of Bid Document	EMD	Essentials*
1	Design, Supply, Installation & Commissioning of Solar Cold Storage/ Cold Room of capacity 5 MT with SPVPP Capacity minimum 4.5 KW.	Rs 5000/-	05 Lakh	<i>* for details pl see eligibility conditions of the bid documents.</i>

Important Events and their schedule for this E.Bid are as follows-

S. No	Particulars	Date	Time	Place
1.	Submission of Bid Documents, Technical Bid	06-08-18	Till 11.30 AM	Office of Superintending Engineer (RE – III), Head Office, CREDA
2.	Examination of Bid Documents & Technical Bid	06-08-18	from 12.30 PM	
3.	Submission of Price Bid through http://cspc.co.in	06-08-18	Till 11.30 AM	http://cspc.co.in Web Portal
4.	Opening of Price Bid	06-08-18	After Technical Bid	At Bio Diesel Conference Hall, Near Energy Education Park, VIP Road, Raipur

Note:-

1. Price Bid shall be submitted online only at <http://www.cspc.co.in>,* however technical bid will have to be submitted in hard copy at Office of Superintending Engineer (RE – III), Head Office, CREDA, Raipur. Bidders are advised to follow the instructions provided for Registration and E Submission Process accordingly.
2. The bid forms, General Instructions to Bidders and other details including amendments/changed can be viewed/ downloaded from website creda.cgstate.gov.in
3. Tender notice is also available on CREDA website creda.cgstate.gov.in in the link notice or <http://www.cspc.co.in>.
4. CREDA reserves all rights to accept/reject any or all tenders in full/part without assigning any reasons.

(Rajiv Khare)
Superintending Engineer

**B. CHECK LIST**

To ensure that your bid submitted to CREDA is complete in all respects, please go through the following checklist & tick mark for the enclosures attached with your bid:

S.No.	Description	Attached / Not Attached	Page no. if attached
1	Bid Document Fee and EMD (proof of submission)		
2	Copy of SI Registration Certificate CREDA in SPV Programme for FY 2018-19.		
3	Submission of Engineering Document with Performance Report of Solar Cold Storage/ Cold Room of capacity 5 MT with SPVPP capacity minimum 4.5 KW from any NABL certified laboratory.		
4	Balance Sheets of last three financial years certified by a registered Chartered Accountant showing positive net worth as on 31-03-2018 and overall cumulative annual turnover of Rs 5 crores in FY 15-16, FY 16-17 & FY 17-18		
5	List with Completion cum Performance Certificates of minimum 100 Nos. of any Decentralized SPV projects installed by the bidder duly certified by a Govt Agency/ Govt UT as on 31-03-2018		
6	Copy of GST Registration Certificate of the bidder.		
7	Original Bid document duly signed & sealed on each page, as a confirmation of acceptance of Terms & Conditions (T&C)		
8	Declaration of the supplier about any relatives working with CREDA		

(Sign & Seal of the bidder)

Details of EMD & Bid Document Fee Attached

S.No.	Description
1	Earnest Money Deposit - Earnest Money Deposit of Rs.5 Lakh, submitted in the form of DemandDraft/ Banker's Cheque/ FDR/ TDR/ NEFT/ RTGS, drawn on Bank, Branch, bearing DD/BC No..... dated.....(*duly pledged in favour of CREDA) is attached herewith.
2	Bid Document Fee - Bid Document Fee of Rs. 5000/-, submitted in the form of DemandDraft/Banker's Cheque, drawn on Bank, Branch, bearing DD/BC No..... dated.....is attached herewith.

(Sign & Seal of the bidder)



C. UNDERTAKING OF THE BIDDER

I/We have read carefully and examined the notice inviting bid, schedule, General Rules and terms and conditions of the contract, special conditions, Schedule of Rates and other documents and Rules referred to in the bid document for the supply.

I/We hereby bid my rates for the execution of the work for CREDA as specified within the time stipulated in the schedule in accordance with all aspects with the specifications, designs, drawings and instructions with such conditions so far as applicable.

I/We agree to keep the bid open for Ninety (90) days from the due date of submission thereof and not to make any modifications in its terms and conditions.

A sum of Rs 5 Lakh (Five Lakh) is hereby forwarded as earnest money in the form of crossed demand draft payable/banker's cheque/TDR/FRD/NEFT/RTGS to CREDA at Raipur (C.G.). If I/We, fail to commence or complete the sanction ordered in specified time I/We agree that the CREDA shall, without prejudice to any other right or remedy, be at liberty to forfeit the said Earnest Money absolutely. The said Earnest Money shall be retained by CREDA towards security deposit to execute all the works referred to in the bid documents upon the terms and conditions contained or referred to therein and to carry out such deviations as may be required by CREDA.

I/We hereby declare that I/We shall treat the bid documents, specifications and other records connected with the work as secret/confidential and shall not communicate information derived there- from to any person other than a person to whom I/We have authorized to communicate the same or use the information in any manner prejudicial to the safety of CREDA/Government.

I/We shall abide to all the laws and shall be responsible for making payments of all the taxes, duties, levies and other Govt. dues etc. to the appropriate Govt. departments.

Our state GST registration no. is _____ . The PAN No. under the Income Tax Act is _____

I/We shall be responsible for the payment of the respective taxes to the appropriate authorities and should I/we fail to do so, I/we hereby authorize CREDA to recover the taxes due from us and deposit the same with the appropriate authorities on their demand.

Dated:

Signature

Place:

Name of bidder with seal

Witness

Signature:

Name:

Postal Address:

D. General Information about this Bid

S.No.	Particulars	Details
1	E.Bid No.	8716/CREDA/HOR/RE-3/Solar Cold Storage/ Cold Room/Bid/2018 Date 05-07-2018.
2	Particulars of the work	Design, supply, installation, commissioning of Solar Cold Storage/ Cold Room Systems with five years comprehensive onsite unconditional warrantee.
3	Time Period for completion of the work	Within 03 Months from the date of allocation of Work.
4	Mode of submission of Bids	Technical Bid – Off Line Price Bid – E Bidding through http://www.cspc.co.in website.
5	Last date and time for submission of Bid and Technical Documents (Offline)	Till 11.30 Hours Date 06-08-2018.
6	Last date and time for submission of Bid and Technical Documents (Online)	Till 11.30 Hours Date 06-08-2018.
7	Period of validity of rates for acceptance	Three months from the date of opening.
8	Date and time of opening of Technical Bid	From 12.30 hours Date 06-08-2018.
9	Date and time of opening of Price Bid	After Technical bid Date 06-08-2018 or on the next date.
10	Place of opening Bid	At Bio Diesel Conference Hall, Near Energy Education Park, VIP Road, Raipur.



E. ELIGIBILITY CRITERIA:

1. Bidder must have valid System Integrator registration in CREDA for SPV Programme for the FY 2018-19.
2. **Bidder should have minimum experience of supply, installation and commissioning of 100 nos of Decentralised Solar Photovoltaic Systems of minimum individual capacity of 01KW as on 31-03-2018. Experience certificate issued by Govt/ Govt Undertaking shall only be considered.**
3. Bidder must have a positive net worth of 10 Lakh as on 31-03-2018.
4. Bidder should have a overall average annual turnover of Rs 5 crores in last three Financial Years ending on 31st March of each FY i.e. FY 2015-16, FY 2016-17, FY 2017-18.
5. Bidder will have to submit audited copy of balance sheet certified by a registered chartered accountant as a proof for point no. 3 and 4 above.
6. Bidder will have to submit a copy of General Assembly drawing along with performance report from any certified laboratory. The test report must assure the technical specifications and performance of the system as per the tender requirement.
7. The Bidder should have valid GST registration certificate. A copy of which should be enclosed.
8. Bidders who are **Blacklisted/Debarred** by CREDA or any other Govt Agency/ Department / UT, **will not be** allowed to participate in this bid.
9. Bidder who has any litigation pending in any court with CREDA on the date of opening of the bid shall not be eligible for this bid.
10. Bidders/System integrator whose registration has been suspended by CREDA due to bad performance or other reasons shall not be eligible to participate in price bid.
11. Any information/data submitted/rendered by the applicant/bidder if found false/forged/wrong would entitle CREDA to reject/cancel the bid submitted by bidder.

F. INSTRUCTIONS TO BIDDER:

1. The Bidder is expected to examine all instructions, forms, terms and specifications as mentioned in the Bid document. Failure to furnish all information required by the Bid documents or submission of a bid not substantially responsive to the Bid Document in every respect will be at the Bidder's risk and is likely to result in out-right rejection of the Bid.
2. Bidder should have a valid system integrator registration in CREDA in SPV Programme.

3. LOCAL CONDITIONS:

It shall be imperative on each bidder to fully inform him of all local conditions and factors, which may have any effect on the execution of the works covered under these documents and specifications. AGENCY shall not entertain any request for clarifications from the Bidder, regarding such local conditions.

4. CLARIFICATION OF BID DOCUMENTS:

- A. A prospective Bidder requiring any clarification of the Bid Documents may contact AGENCY in writing or by Fax at the AGENCY's mailing address indicated in the Invitation for Bid.
- B. Verbal clarifications and information's given by the AGENCY or its employees or its Representatives shall not be in any way entertained.

5. AMENDMENT OF BID DOCUMENTS:

At any time prior to the submission of the bid or prior to the opening of the financial bid the AGENCY may, for any reason, whether at its own initiative or in response to a clarification requested by the Bidder, modify the Bid documents by amendments.

6. **BIDDING PROCESS-** For ease of accessing the e-bidding website and registration the following is to be done by bidder –
 - A. Visit <http://www.cspc.co.in>
 - B. Click on e-bidding button on right hand side of the page.
 - C. The user will be directed to e-bidding page where all information regarding registration is available along with helpline details.
 - D. The Bidder must submit attested copies of all legal documents pertaining to the constitution of their Concern as applicable, along with the Tender, to authenticate their identity, such as affidavit of Sole Proprietorship/Partnership Deed/ Registration Certificate/ Certificate of incorporation of the Company/Memorandum of Association of the Company and Power of Attorney authorising a person to represent the firm in all matters with respect to the Bid.
 - E. Price Bid shall be submitted online only at <http://www.cspc.co.in> however technical bid will have to be submitted in hard copy. Bid Documents (including Technical Bid) must reach At Office of Superintending Engineer (RE – III), Head Office, CREDA latest by 11.30 AM on 06.08.2018. Tenders submitted after scheduled time and date shall not be considered.
 - F. Technical Bid Documents should be submitted in prescribed manner in separate envelopes duly super scribed and placed as follows- (A)Bid Fees and EMD , (B) Eligibility Documents as per point E(1) to E(11) mentioned above (C) Technical Bid and Complete bid document in original duly signed by authorized signatory on each & every page of the bid document.
 - G. The envelopes must be clearly marked as “(A)Bid Fees and EMD /(B) Eligibility Documents / (C) Technical Bid and Complete bid document in original /of “**BID DOCUMENT NO.8716/CREDA/HOR/RE-3/Solar Cold Storage/Cold Room/2018 Date 05-07-2018 DUE ON 06-08-18**”.



7. The Specifications of Solar Cold Storage/ Cold Room Systems should be as specified in the bid.
8. Bidder shall have to submit details of GST & PAN registration numbers issued by the appropriate authority
9. The documentary evidence for meeting the eligibility criteria must mandatorily be submitted along as per check list with bid in prescribed manner.
10. Each offered solar module should have RFID & I-V curve measured with a sun simulator of a SPV Module Manufacturer reregistered/approved by MNRE with record of suitable calibration reference, as per guidelines of MNRE.
11. Bidders must enclose the safety procedure & manual.
12. When Technical Bid Documents & Eligibility documents are delivered through messenger, it should be submitted at Office of Superintending Engineer (RE - III), Head Office, CREDA latest by 11.30 AM on 06.08.2018. Nobody is authorized to receive or grant receipt for tender delivered on behalf of CREDA.
13. Bidder should quote their rates considering variation of site conditions, variation in price of different components and keeping the quantum and quality of work in mind. If CREDA anticipates that rate is abnormally low or high, CREDA shall have liberty to amend the rates or reject the bid.
14. **VALIDITY:** Full descriptive particulars and complete specifications should accompany the offer. Offers should be kept open for acceptance for at least three months from the date of opening. After finalization of this bid the approved rates shall be valid till one year from the date of award; however CREDA shall have liberty to increase or decrease this validity if needed.
15. The terms, conditions and specifications mentioned in bid document shall be binding on the bidders and no condition or stipulation contrary to the conditions shall be acceptable. It may please be noted that the bidders who do not accept terms and conditions stipulated in this bid documents, their offers shall be liable to be rejected out-rightly without assigning any further reasons.
16. Each page of bid document & enclosures shall be signed by the bidder and seal affixed. All the pages of the documents issued must be submitted along with the offer. In case of any corrections/ alterations in the bid, the bidder should attest the same; otherwise bids may not be considered.
17. CREDA reserves the right (i) to reject or accept any or all tenders wholly or partly without assigning any reason on the grounds considered advantageous to CREDA, whether it is the lowest tender or not and (ii) to split the quantities against the tender on more than one firm for the same items/ work. No reason will be assigned by CREDA for this and will be binding on the bidders. The bidder who had quoted the lowest price shall be preferred for placing order. Due to large quantum of work & limitation of the time period for completion of the work CREDA shall take consent from more than one bidder if they agree to work on rates standardized by CREDA. CREDA may undergo agreement with those eligible bidders who give consent to work on rates standardized by CREDA and may place work orders to them. **Rates approved through this tender may be standardized for all eligible tenders to work in year 2018-2019 and shall be valid till 31-03-2019.** However CREDA reserves right to curtail or extend this period.

18. Offers through Telegraph/ Fax/Emails or open offers etc. received shall be summarily rejected.
19. All the bidders shall essentially indicate the break-up of prices as shown in Price Bid. In case any of the charges are not included in the quoted prices, the same shall be clearly shown as extra, indicating specifically the rate/scale of such charges. The lowest prices quoted shall be considered.
20. **BID DOCUMENT FEE AND EARNEST MONEY:**
Each bidder should submit Bid Document Fee and earnest money 5 Lakh for participating in bid in the form of Demand Draft/Pay Order or RTGS/NEFT/FDR/TDR as mentioned in the NIT of **BID DOCUMENT NO.8716/CREDA/HOR/RE-3/Solar Cold Storage/Cold Room/2018 Date 05-07-2018**, in a separate envelope else they will summarily be rejected and returned. Bid Document Fee, EMD submitted in any other form e.g. Cash/Bank Guarantee etc shall not be accepted. [Exemption from EMD shall be given only to those SSI units of Chhattisgarh State who submit the competency certificate on which it should be clearly mentioned that, “the company registered in Chhattisgarh for manufacturing of that particular product”]. CREDA Competency Certificate will not be considered as EMD for this Rate Contract Bid.
21. **FORFEITURE OF EARNEST MONEY DEPOSIT:**
It should be clearly understood that in the event of bidder failing to enter into the agreement in the prescribed format on their quoted rates and also fails to execute assigned works within stipulations, if he is so communicated within the validity period of the offer, the full amount of earnest money shall be forfeited and bidder will be debarred from future business with CREDA. CREDA's decision in this respect will be final and binding on the bidder.
22. **PRICE:**
The prices quoted should be firm and F.O.R. destination excluding GST payable on the bill of supply and installation / services. GST as applicable on the date of billing shall be paid additionally as per applicable rate over the above quoted prices
23. **ENGINEERING DOCUMENT & TEST CERTIFICATE:**
Bidders will have to submit Engineering Documents with technical details, drawings, Specifications & Performance Report from any certified laboratory.
24. **SAMPLES:**
If Require CREDA may inspect the consignment before dispatch of the material at shall be delivered/ accepted as per the scope of work and specifications, as get it tested in accreted laboratory at its own cost.
25. **TAX OBLIGATIONS:**
TDS for Income Tax, GST, Civil Work etc shall be recovered under various acts and deposited with the appropriate authority. Eligible bidder will have to submit break up of costs and taxes before execution of agreement with CREDA so as to ensure tax deposition as per Govt Rules accordingly.
26. **JURISDICTION OF THE COURT:** Any dispute arising out of the contract shall be subject to the jurisdiction of court in Chhattisgarh.

G. GENERAL CONDITIONS OF CONTRACT

1. **DEFINITIONS:** In writing General Conditions of Contract, the specifications and bill of quantity, the following words shall have the meanings hereby indicated, unless there is something in the subject matter or content inconsistent with the subject.

CREDA shall mean the Chhattisgarh State Renewable Energy Development Agency represented through the CEO.

Work shall mean any work entrusted to the bidder as mentioned in the scope of work and sanction order.

The "Engineer in charge" shall mean the Engineer or Engineers authorized by CEO, CREDA for the purpose of this contract. Inspecting Authority shall mean any Engineering person or personnel authorized by CREDA to supervise and inspect the erection of the Solar Cold Storage System/ Cold Room.

"The Eligible SI/ bidder" shall mean the bidder awarded with the contract or their successors and permitted assigns. Contract Price shall mean the sum named in or calculated in accordance with the provisions of the contract as the contract price. General Conditions shall mean the General conditions of Contract.

"Specifications" shall mean the specifications annexed to these General Conditions of contract and shall include the schedules and drawings attached thereto or issued to the eligible SI from time to time, as well as all samples and pattern, if any,

"Month" shall mean calendar month. "Writing" shall include any manuscript, typewritten, printed or other statement reproduced in any visible form whether under seal or written by hand.

2. **CONTRACT DOCUMENT:**

The term "Contract" shall mean and include the General conditions, specifications, schedules, drawings, work orders etc., issued against the contract schedule of price or their final general conditions, any special conditions applying to the particular contract specification and drawings and agreement to be entered into. Terms and conditions not herein defined shall have the same meaning as are assigned to them in the Indian contract Act or any other Act in vogue or by any person of common knowledge and prudence.

3. **MANNER OF EXECUTION:**

Execution of work shall be carried out in an approved manner as outlined in the technical specifications or where not outlined, in accordance with desired Specifications laid down by CREDA, to the reasonable satisfaction of the Engineer.

- i) The eligible Contractor shall conduct a detailed survey of site and submit Site Clearance and necessary documents and survey details in concerned District Office of CREDA in prescribed manner.
- ii) District / Regional Office CREDA shall examine these reports and after satisfaction forward these to concerned Superintending Engineer of Head office of CREDA for approval.
- iii) The Contractor shall start work within 15 days after the date of issue of work Order. Work order will be given to the chosen System Integrator only after execution of the agreement with CREDA.

- iv) All the materials required for the installation of **Solar Cold Storage/ Cold Room** as per Work Order issued shall be kept at site in the custody of the SI. CREDA shall not be responsible for any loss or damage of any material during the installation.
- v) All the electrical works should be done as per Indian electricity Act. The persons engaged for carrying out electrical works should have a valid license of required category accordingly.
- vi) After installation and joint inspection will be done in presence of beneficiary, SI and CREDA and after successful commissioning of **Solar Cold Storage/ Cold Room** and its approval from CREDA a JCC will be signed and the claim will be forwarded for payments as per guidelines and procedures of CREDA.

4. VARIATIONS, ADDITIONS & OMISSIONS:

CREDA shall have the right to alter, amend, omit, split or otherwise vary the quantum of work, by notice in writing to the SI. The eligible SI shall carry out such variation in accordance with the rates specified in the contract so far as they may apply and where such rates are not available; those will be mutually agreed between CREDA and the eligible SI.

5. INSPECTION DURING ERECTION:

The Engineer in Charge or his authorized representative (s) shall be entitled at all reasonable times to inspect and supervise and test during installation and commissioning. Such inspection will not relieve the eligible SI from their obligations under this contract. Material can be inspected before dispatch by the authorized representatives of CREDA at the factory at the cost of the eligible SI, if desired by CREDA.

6. COMPLETION OF WORK:

Time being the essence of contract, the installation of the **Solar Cold Storage/ Cold Room** shall be completed within the time schedule prescribed in the Work order.

7. ELIGIBLE SIs DEFAULT LIABILITY:

CREDA may by written notice of default to the eligible SI, terminate the contract in circumstances detailed hereunder:

- (a) If in the opinion of the CREDA, the eligible SI fails to complete the work within the time specified in the Work Order or within the period for which extension has been granted by CREDA to the eligible SI.
- (b) If in the opinion of CREDA, the eligible SI fails to comply with any of the provisions of this contract.
- (c) In the event of CREDA terminating the contract in whole or in part as provided in paragraph (a) above, CREDA reserves the right to engage another eligible SI or agency upon such terms and in such a manner as it may deem appropriate and the eligible SI shall be liable to CREDA for any additional costs or any losses caused to CREDA as may be required for the completion of erection of the **Solar Cold Storage/ Cold Room** and or for penalty as defined under this bid document until such reasonable time as may be required for the final completion of the work.
- (d) In the event CREDA does not terminate the contract as provided in paragraph (a) the eligible SI shall continue performance of the contract, in which case he shall be liable to CREDA for penalty for delay as set out in this bid document until the work is completed.
- (e) The maximum liability of the bidder is limited to 100% of contract value.

8. FORCE MAJEURE:

The eligible SI shall not be liable for any penalty for delay or for failure to perform the contract for reasons of FORCE MAJEURE such as of God, acts of public, enemy, naxal problems, acts of government, cyclone, fires, floods, epidemics, quarantine restrictions, strikes, freight embargoes provided that the contract, shall within 10 (ten) days from the beginning of such delay notice the CREDA in writing of the cause of delay. CREDA shall verify the facts and grant such extension as facts justify. Delay in supply of any accessories of Solar Cold Storage/ Cold Room by the related vendors, to whom the bidder has placed order, shall also not be treated as force majeure.

9. REJECTION OF WORKS:

In the event of any of the material supplied/ work done by the eligible SI is found defective in material or workman ship or otherwise not in conformity with the requirements of this contract specifications, CREDA shall either reject the material and/ or work and advise the eligible SI to rectify the same. The eligible SI on receipt of such notices shall rectify or replace the defective material and rectify the work, free of cost. If the eligible SI fails to do so, CREDA may,

- i At its option replace or rectify such defective materials and/ or work and recover the extra cost so involved from the eligible SI plus fifteen percent service charges of the cost of such rectification, from the eligible SI and/ or terminate the contract for balance work/ supplies with enforcement of penalty as per contract
- ii Defective materials/ workmanship will not be accepted under any conditions and shall be rejected outright without compensation. The eligible SI shall be liable for any loss/ damage sustained by CREDA due to defective work.

10. EXTENSION OF THE TIME:

If the completion of installation is delayed due to any reason beyond the control of the eligible SI, the eligible SI shall without delay give notice to the CREDA in writing of his claim for an extension of time. CREDA on receipt of such notice may agree to extend the contract/delivery date of the Solar System as may be reasonable but without prejudice to other terms and conditions of the contract.

11. MAKES OF EQUIPMENTS TO BE USED IN THE WORK:

The eligible SI has to ensure that equipments as per Technical Requirements of guidelines of CREDA as complied with. The eligible SI has also to ensure that he will use only components of approved vendors of CREDA. The material/works for which CREDA/MNRE or IEC/BIS/IS specification is not available, engineer-in-charge of the works will examine and approve the material/works, preferably of all makes on which CREDA has report of satisfactory performance. Test certificates for all major equipments should be submitted to the engineer-in-charge of the works before installation of the same.

12. WARRANTEE PERIOD AND POST INSTALLATION SERVICES:

The work done/ material supplied by the eligible SI should be warranted for satisfactory operation and against any defect in material and workmanship including Luminaries, Controllers and other balance of equipments, at least for a period of 5(five) years, from the date of commissioning of the Solar Cold Storage/ Cold Room including other works as per scope of work. Warrantee on SPV Modules shall be for 10 (ten) years from the date of commissioning of the Solar Cold Storage/ Cold Room must be warranted for their output peak

watt capacity, which should not be less than 90% at the end of 10 years and not less than 80% at the end of 25 years. The above warrantee certificates shall be furnished to the CREDA for approval. Any defect noticed during this period should be rectified by the supplier free of cost upon written notice from CREDA provided such defects may be due to bad workmanship or bad materials used. The warrantee period shall be extended by the period during which the plant remains non-operative due to reasons within control of the eligible SIs. This warrantee must be an unconditional onsite warrantee and the eligible SI will have to replace the defective material within 7 days positively from the date of information given to him. Care should necessarily be taken to make the **Solar Cold Storage/ Cold Room** operational, once the reporting of the fault/non operational status is done, within a week. If the **Solar Cold Storage/ Cold Room** is not made operational within 7 days CREDA may rectify the same at the cost of SI, and the warrantee period shall be extended for a month for the same. This warrantee must be an unconditional onsite warrantee and the eligible SI will have to replace the defective material within 7 days positively from the date of information given to him.

System Integrators shall have to establish their service stations in the state and shall have to keep sufficient quantity of spares and man power to ensure proper service network for taking care of smooth functioning of **Solar Cold Storage/ Cold Room** System installed by them. SI shall have to give a toll free number to register complaints.

13. TERMS OF PAYMENT:

The following terms of payment shall apply for the bid: -

- a) 95% of the cost as per the work order after satisfactory supply, installation, commissioning & performance test of the **Solar Cold Storage/ Cold Room** System at site with proper handing over.
- b) Balance 5% of the cost of the system as per the work order shall be retained by CREDA as Security Deposit for a period of 60 months. However the same may be released to SI on submission of bank guarantee or TDR (duly pledged in favour of CREDA) of equivalent amount in prescribed format valid for a period of five years issued by a scheduled bank. Payment will be done after receipt of Beneficiary contribution to CREDA.
- c) GST shall be paid extra as applicable on the date of billing.

14. PENALTY FOR DELAY IN COMPLETION OF CONTRACT:

If the eligible SI fails to complete the erection, testing and commissioning etc, within the phased time schedule specified in the work order or any extension granted there to, CREDA will recover from the eligible SI as penalty a sum of half percent (0.5%) of the system price of the uncompleted portion of the work for each week of delay or part thereof. For this purpose, the date of taking over shall be reckoned as the date of completion. The total penalty shall not exceed 5% (five percent) of the Cost.

Penalty may be recovered from payments due or by invocation of performance security. CREDA may also debar the SI from future business for upto 3 years in case of non performance of work in time limit.

15. PERFORMANCE SECURITY:

The Performance Security shall be 5% of the eligible payments and shall be deposited in manner under clause no. 13. For the purpose of 13(b) the EMD may be considered to be converted into part of performance security. EMD shall be refunded only upon submission of at least equal amount towards Performance Security or else EMD shall be deemed to be converted into Performance Security.

16. **INSURANCE:** The eligible SI shall arrange insurance coverage for the materials and **Solar Cold Storage/ Cold Room** at his/beneficiary's custody for the work under execution and successful commissioning and subsequent handover to the beneficiary. The eligible SI shall take up insurance or such other measures for the manpower so as to cover the claim for damage arising under workmen's compensation Act and other applicable State/ Central laws. CREDA shall not bear any responsibility on this account.
17. **PENALTY DUE FROM THE ELIGIBLE SI:**
All costs of damages for which the eligible SI is liable to the CREDA will be deducted from any money due to the eligible SI including the security deposit.
18. **ELIGIBLE SI'S RESPONSIBILITY:**
Notwithstanding anything mentioned in the specifications of subsequent approval or acceptance of the **Solar Cold Storage/ Cold Room** by CREDA, if any, the ultimate responsibility for satisfactory performance of the entrusted work shall rest with the eligible SI. If in any case the eligible SI does not complete the work as per the Work orders issued to them then CREDA may take over the task & complete the project at the cost of eligible SI.
19. **RESPONSIBILITY TO RECTIFY THE LOSS AND DAMAGE:**
If any loss or damage occurs to the work or any part thereof or materials/ plant/ equipment for incorporation therein the period for which the eligible SI is responsible for the cause thereof or from any cause whatsoever, the eligible SI shall at his own cost rectify/ replace such loss or damage, so that the permanent work confirms in every respect with the provision of the contract to the satisfaction of the Engineer. The eligible SI shall also be liable for any loss or damage to the work/ equipment occasioned by him in course of any operation carried out to him during performing the contract.
20. **RESPONSIBILITY TOWARDS THE WORKMAN OR OUT SIDERS:**
The eligible SI shall have to take insurance coverage from any authorized Insurance Company against Workmen compensation due under Workmen Compensation Act and submit copy of the insurance document before issuance of Sanction order. The eligible SI shall ensure all safety measures during execution and repairs of the work. CREDA, will, in no case be responsible for any accident fatal or non-fatal, caused to any workman or outsider in course of transport or execution or repairs of work. All the expenditure including treatment or compensation will be entirely borne by the eligible SIs. The eligible SI shall also be responsible for any claims of the workers including PF, Gratuity, ESI & other legal obligations.
21. **NON-ASSIGNMENTS:**
The eligible SI shall not assign or transfer the work orders issued as per this contract or any part thereof without the prior approval of CREDA.
22. **CERTIFICATES NOT TO AFFECT RIGHTS OF CREDA:**
The issuance of any certificate by CREDA or any extension of time granted by CREDA shall not prejudice the rights of CREDA in terms of the contract nor shall they relieve the eligible SI of his obligations for due performance of the contract.
23. **SETTLEMENT OF DISPUTES THROUGH ARBITRATION:**
- i. Except as otherwise specifically provided in the contract, all disputes concerning questions of fact arising under the contract shall be decided by the Chief Executive Officer (CEO), CREDA provided a written appeal by the eligible SI is made to CREDA. The decision of the CEO, CREDA shall be final and binding to the all concerns.
 - ii. Any dispute or difference including those considered as such by only of the parties arising out of or in connection with the contract shall be to the extent possible be settled amicably between the parties. If amicable settlement cannot be reached then all disputed issues shall be settled by arbitration.

24. LAWS GOVERNING CONTRACT:

The contract shall be constituted according to and subject to the Laws of India and jurisdiction of the High Court of Bilaspur, Chhattisgarh.

Compliance with Labour Regulations-During continuance of contract, the contractor shall abide at all times by all applicable existing labour enactment and rules made there under, regulations, notifications and bye laws of state and central Govt or local authority that may be passed/issued or may be issued.

25. LANGUAGE AND MEASURES:

All documents pertaining to the Contract including specifications, schedules, notice correspondences, operating and maintenance instructions, drawings or any other writings shall be written in English / Hindi language. The metric system of measurement shall be used in this contract.

26. CORRESPONDENCE:

- i. Any notice to the eligible SI under the terms of the contract shall be served by registered mail to the registered office of the eligible SI or by hand to the authorized local representative of the eligible SI and copy by post to the eligible SI's principal place of business.
- ii. Any notice to CREDA shall be served to the CEO, CREDA, Raipur in the same manner.

27. SECRECY:

The eligible SI shall treat the details of the specifications and other documents as private and confidential and they shall not be reproduced without written authorization from CREDA.

28 AGREEMENT:

The successful eligible SI shall have to enter into an agreement with the CEO, CREDA in the approved contract agreement form within 07 days of the receipt of call from CREDA.

29. BID EVALUATION CRITERIA

- i. Offers of only those parties who are found qualifying based on eligibility Criteria will be taken into further consideration and only those parties qualifying based of these criterion will be allowed to submit their price bid.
- ii. Bids shall be evaluated on the basis of rates without GST.
- iii. CREDA retains right to negotiate rates with L-1 Bidder.
- iv. L-1 Rates or the rates approved by CREDA will be considered as the final rate of the project.
- v. Conditional bids shall not be accepted.
- vi. However CREDA shall have rights and liberty to call any /other parties to work on approved rates as and when requires in accordance with quantum of work and scheduled time limits for completion of targets.

30. ALLOCATION OF TARGETS AND AREA OF WORK

- (a) L1 bidder will be given preference for allocation and they will be awarded min. 25% of the Work.
- (b) Initially all the eligible SI will be awarded with equal nos of work. However further allocations shall be made on the basis of their performance subsequently.

We (on behalf of Eligible SI/bidder) have read all the above stated details & accept to comply with it in total.

(Name, Signature & Seal of thebidder)

H. SCOPE OF WORK

The scope in brief will be as follows-

1. Survey of Sites, designing, supply, installation & commissioning of **Solar Cold Storage/ Cold Room** including Cold Storage, SPVPP, Thermal Storage Backup and Cold Storage Room as per design and specifications approved by CREDA. Bidder shall have to take approval of the engineering documents and Bill of Materials from CREDA prior to commencement of the work. Five years onsite warrantee for manufacturing defects shall be required for each of the system after successful commissioning and proper handing over.
2. The scope of work shall also includes the followings:
 - Survey of Sites, Submission of site clearance certificate where the SPV Cold **Storage/ Cold Room** to be installed. A layout plan of the site should also be submitted clearly indicating the identified location for installation of SPV Modules, Refrigeration System, Thermal Storage Backup, Cold Storage Room, Structures, other components with necessary civil works shall have to be submitted. Work order shall be issued only after receipt of satisfactory reports suitable for system installation. SI shall furnish all necessary information to beneficiary for **Solar Cold Storage/ Cold Room** Warrantee, Do & Don'ts etc. so as to avoid further misunderstandings and disputes
 - The company has to do post harvest management training session for the beneficiary where in they need to assist them with how to use the product and also provide them **software based forward** linkage support so that the utility of the system is ensured.
 - Detailed planning of time bound smooth execution of project.
 - Design, supply, installation & commissioning of **Solar Cold Storage/ Cold Room** System of required capacities as per design and specifications approved by CREDA.
 - Providing User Manuals and Warrantee Cards to beneficiary / CREDA.
 - SI shall have to submit JCCs within 15 days of Installation and Commissioning of **Solar Cold Storage/ Cold Room** in District Office of CREDA.
 - On-site warrantee for manufacturing defects for Five years faultless operation, assure inventory for maintenance.
 - Providing Prompt Service Facilities to customers/ beneficiaries.
 - Risk liability of all personnel associated with implementation and realization of the project.
 - Training of at least two persons nominated by user, on the various aspects of design and maintenance of the offered system after commissioning of the system.
 - The eligible SI shall maintain sufficient inventory of the spares to ensure that the system can be made functional within 7 days from the communication of breakdown of the system during currency of the warrantee period.

The contractor shall run the system on trial basis and shall closely monitor the performance of the system before handing over the system, so that the assured annual power generation can be estimated for monitoring of the performance of the system. CREDA shall examine the data of generation and ascertain if the generation is adequate with reference to the capacity of the SPV Systems.
 - Performance Guarantee Test: Successful performance guarantee test to demonstrate the rated capacity of **Solar Cold Storage/ Cold Room** as per CREDA's norms shall have to be conducted by SI in presence of representatives of CREDA, if required.

I. TECHNICAL SPECIFICATIONS:

Technical specifications of Solar Cold Storage/ Cold Room (1 MT pre-cooler with 5MT staging)

The proposed unit is a solar powered cold room with thermal storage back up for storage of fresh produce – fruits, vegetables & flowers specifically.

The unit has dimensions of 20ft x 8ft x 8ft with solar panels mounted on the roof top of the unit. The cold room maintains a temperature in the range of 4C to 10C. The system has battery-less compressor operation. A small battery is provided to operate only the auxiliary loads and the control system.

1. Technical Specifications – to be verified by third party certified laboratory

A. Refrigeration System - 1 MT Pre cooling + 5 MT Staging

- Variable Speed Compressor with battery-less operation
- Temperature control: 4-10 C
- Power Supply: 300 – 800 V DC and (230 V, 1 Ph, 50 Hz or 415 V, 3 Ph, 50 Hz or Diesel Generator Hybrid)
- Minimum Refrigeration Capacity: 1.8 TR / 21600 BTU
- Evaporator Power Supply: 24/48 VDC, 3 numbers of Fan and Motor

B. Thermal Energy Storage

- Phase change material-based energy storage
- Convection based temperature control
- Upto 30 hrs backup

C. Cold Room

- External Dimension: 20 ft X 8 ft x 8 ft
- 100 mm thick PUF Panels enclosed with 0.5 mm thick PPGI sheet or equivalent insulation
- Heavy duty door
- Fully portable unit through galvanized iron based provision for loading, unloading, transportation
- Galvanized iron based Mounting structure for solar panels on the cold room
- Provision for Humidity control

D. Power System and Control System

- Minimum 4.5 kWp Solar PV Polycrystalline
- Drive Control
- Power Convertors
- Minimum 24 V, 100 Ah batteries for auxiliary power supply

E. Control System

- Control System for Fans, Valves, Compressor etc.
- Android app based remote control via Bluetooth
- Commodity-specific, picture based set point control

F. Other

- Remote Monitoring Mobile Application along with the handset
- Predictive Maintenance
- Post-Harvest Management Training and consulting

2. Performance parameters of solar cold Storage/ Cold room : (to be verified by any NABL certified laboratory)

1. The cold Storage/ Cold room should be able to maintain a temperature between 4 C to 10 C based on commodity requirement meaning if the user wants to maintain 6 C, he/she should be able to set and maintain 6 C at steady state conditions.
2. The cold room should be able to hold at least 5000 kgs of a commodity equivalent to oranges and with a provision to hold at least 250 numbers of standard 20 kg crates.
3. The cold Storage/ Cold room should be able to pre-cool or pull down the temperature of a commodity equivalent to Oranges (equivalent in terms of specific heat and respiration rate) from 30 C to 5 C in 6 hours, ambient temperature being 40 C peak and 35 C on average during the day. The quantity of commodity to be pre-cooled should be at least 500 kgs for standalone solar operation and 1000 kgs for grid operation
4. The cold room should be able to maintain a temperature for a period of at least 30 hours on a typical day having 40 C peak ambient temperature and 35 C average temperature with a commodity loading equivalent to 5000 kgs without any power source being available if the backup system is completely charged
5. The cold Storage/ Cold room should automatically shift to grid power if solar is not sufficiently available.
6. The cold Storage/ Cold room should automatically shift to diesel generator if solar is not sufficient for operation and grid power is not present. Provision to auto-start and shut off diesel generator is mandatory.
7. The cold Storage/ Cold room must have a remote monitoring unit to monitor various aspects including but not limited to the following:
 - a. room temperature, room humidity
 - b. ambient temperature, ambient humidity
 - c. compressor power consumption
 - d. whether the door is open or closed

The monitoring should be done at an interval of not more than 2 minutes.

3. SPV MODULE:

- i. Indigenously manufactured PV module should only be used.
- ii. The PV module should have crystalline silicon solar cells and must have a certificate of testing conforming to IEC 61215 Edition II / BIS 14286 from an NABL or IEC accredited Laboratory.
- iii. The power output of the module(s) under STC should be a minimum of as per the model at a load voltage of 16.4 ± 0.2 V.
- iv. The open circuit voltage* of the PV modules under STC should be at least 21.0 Volts. Or as per MNRE
- v. The module efficiency should not be less than 15 %.

- vi. The terminal box on the module should have a provision for opening it for replacing the cable, if required.
- vii. There should be a Name Plate fixed inside the module which will give:
 - a. Name of the Manufacturer or Distinctive Logo.
 - b. Model Number
 - c. Serial Number
 - d. Year of manufacture
- viii. A distinctive serial number starting with NSM will be engraved on the frame of the module or screen printed on the tedler sheet of the module.

4. QUALITY AND WARRANTY:

- i. The **Solar Cold Storage/ Cold Room** System will be warranted for a period of five years from the date of supply.
- ii. The PV module(s) will be warranted for a minimum period of 10 years from the date of supply. The PV modules must be warranted for their output peak watt capacity, which should not be less than 90% at the end of Ten (10) years and 80% at the end of Twenty five (25) years.
- iii. The Warranty Card to be supplied with the system must contain the details of the system.

5. DO's and DONT's:

Name and address of the contact person for repair and maintenance, in case of non-functionality of the Solar Cold Storage/ Cold Room System.

I. PROPOSED LAYOUT OF SOLAR COLD STORAGE/COLD ROOM

Layout - 1

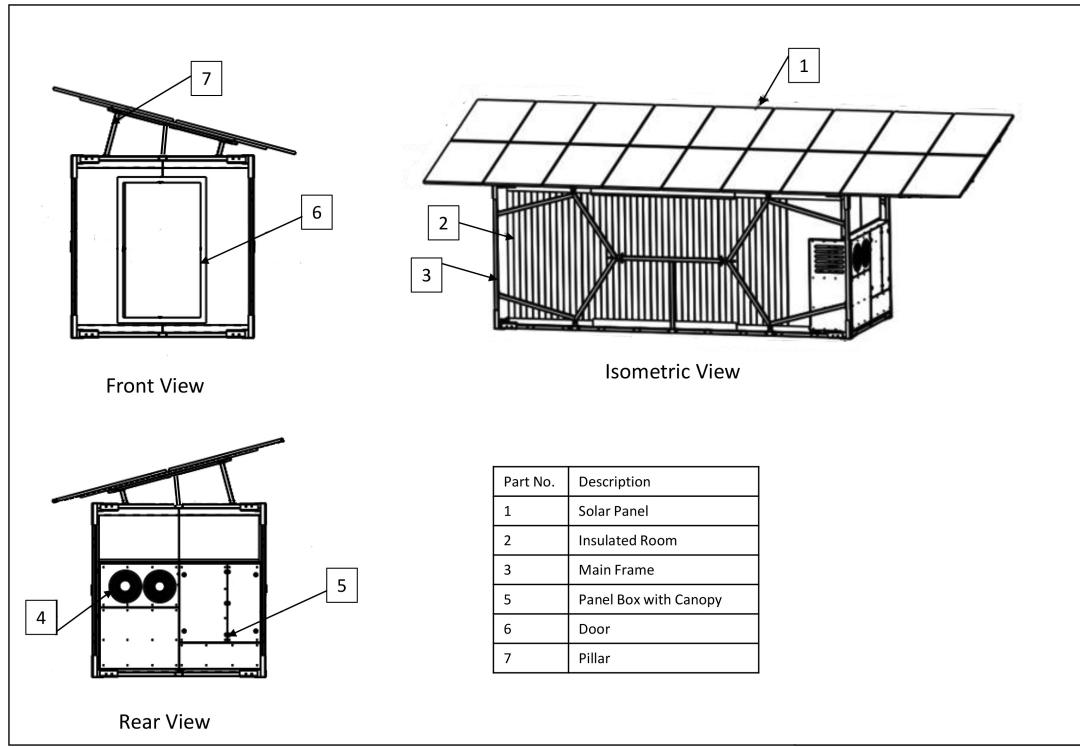

Layout - 2

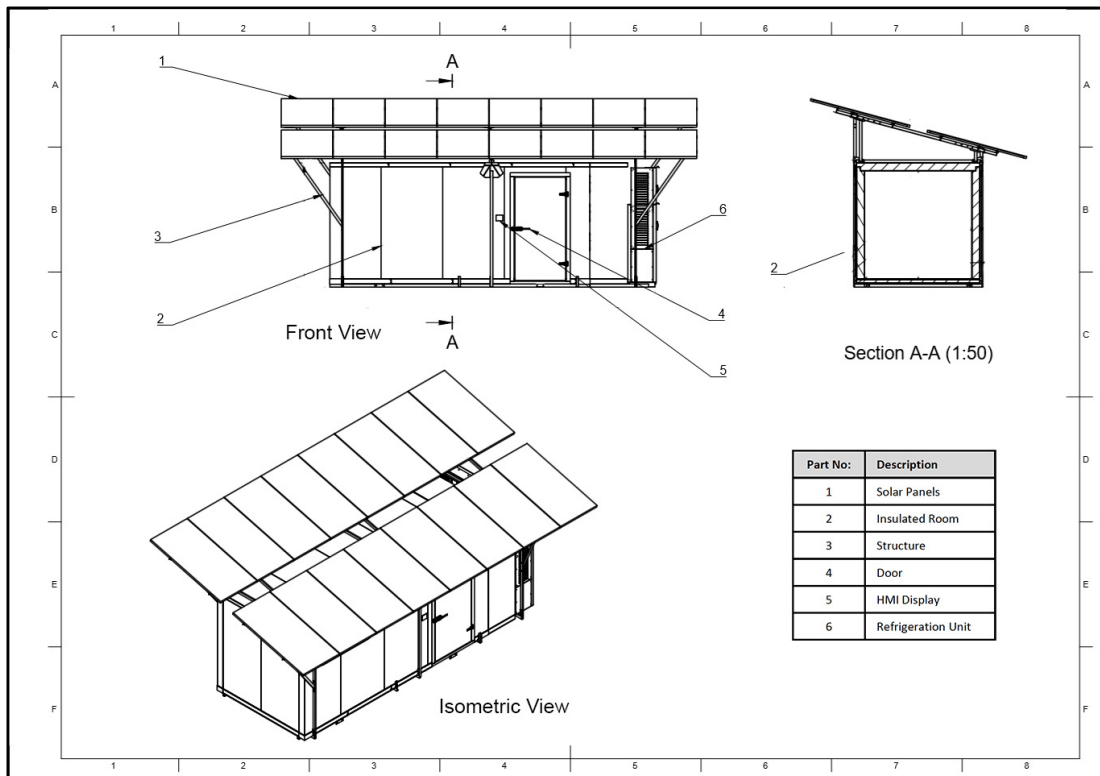

Scope of Civil Work

Cold Storage Placement Layout and Guidelines

- Solar Cold Storage to be put on Platform as shared in Design.
- Solar Cold Storage to be designed as the maximum length will be from East to West.

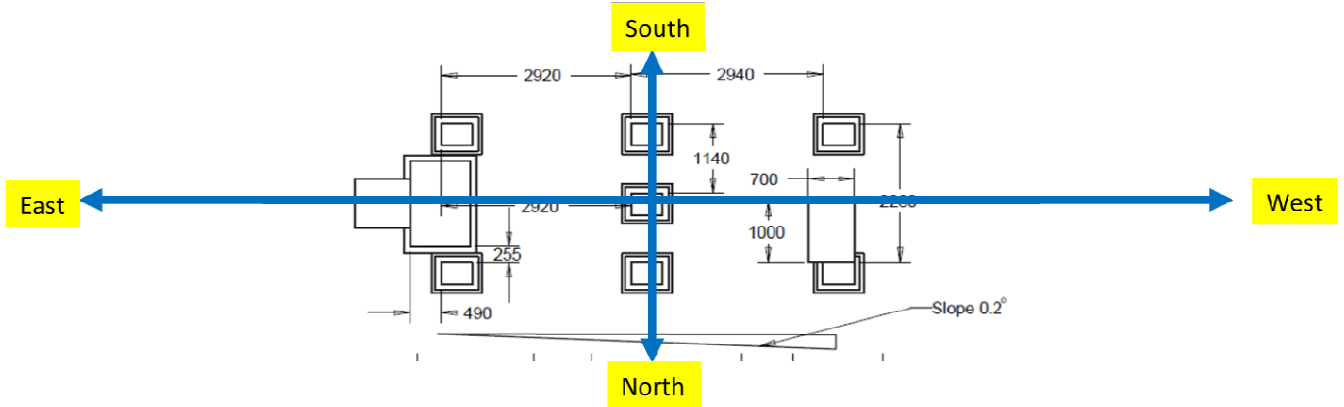

- Slope of 0.2 degree needs to maintained along the length of the system.
- No shadow from trees or buildings should fall on Cold Storage at any time of the day.
- Water logging near cold storage to be avoided

Pillar Dimensions and Drawing

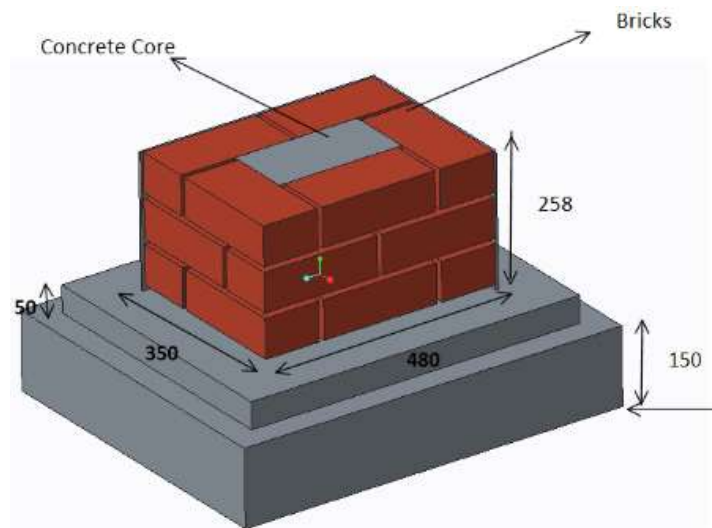



K.

PRICE BID.

Schedule of Rates for Solar Cold Storage/Cold Room Systems.

(As per Specifications & Scope of Work of

E.Bid Document No.8716/CREDA/HOR/RE-3/Solar Cold Storage/ Cold Room/2018 Date 05-07-2018)

Design, Supply, Installation and Commissioning of **SPV Cold Storage/ Cold Room Systems** including civil work foundation and other allied works with five years on site unconditional warrantee at various sites of Chhattisgarh State as per scope of work.

No.	Description	Rate/ Unit (without GST)
1	Supply of Solar Cold Storage/ Cold Room system of capacity 05 MT with SPVPP capacity – min 4.5 KW and all accessories at site	
	Installation and Commissioning at site	
	IOT Portal for forward linkage with mobile based app & on-field post harvest management training sessions for proper utilisation of the unit	
	Comprehensive Operation and Maintenance of Systems for five years	
TOTAL		

Certified that rates quoted above are as per the requirement, specifications, and terms & condition mentioned in the bid document.

Above rates are FOR anywhere in the State of Chhattisgarh inclusive of roadworthy packing, loading, unloading, all types of incidental expenses, insurance, duties and any other job required to properly execute the work with 5 years warrantee as mentioned in the bid document. The GST payable on the bill produced for payment to CREDA shall be paid in addition to above quoted price as per rate of GST applicable at the time of billing.

(No other cost will be claimed above the price quoted)

Name of the authorized Signatory:

Signature of the Authorized Signatory:

Seal of Company:

Date: